



Specification

Model	FRL		
Port size	1/4	3/8	1/2
Medium	Air		
Operating pressure range	0 ~ 15 Bar.		
Proof pressure	20 Bar.		
Regulated pressure range	Standard type: 1 ~ 8.5 Bar.		
	High pressure type: 1 ~ 15 Bar.		
Ambient temperature	(-5) ~ + 60 °C (No freezing)		
Filter element	Standard: 40 μm Option: 5 μm		
Lubricating oil capacity	200 cc		
Min. Flow for oil drip	30 l/min	65 l/min	80 l/min
Recommended lubricating oil	Turbine oil ISO-VG32		
Attachment	Pressure gauge (PG-20), L-type bracket		
Weight	1518 g.		

Order information

FRL - X05 - C02

MODEL

X05: 1/4"

X06: 3/8"

X07: 1/2"

X08: 3/4"

X09: 1"

C02: 2 Combo

C03: 3 Combo

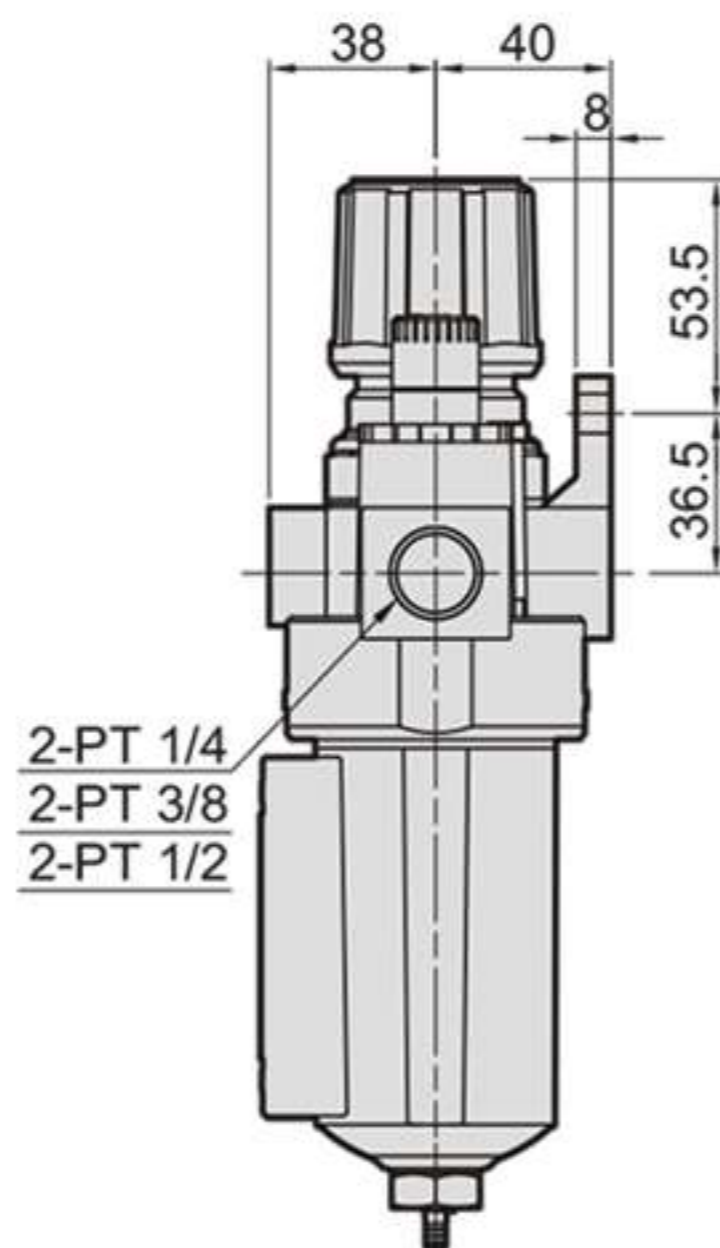
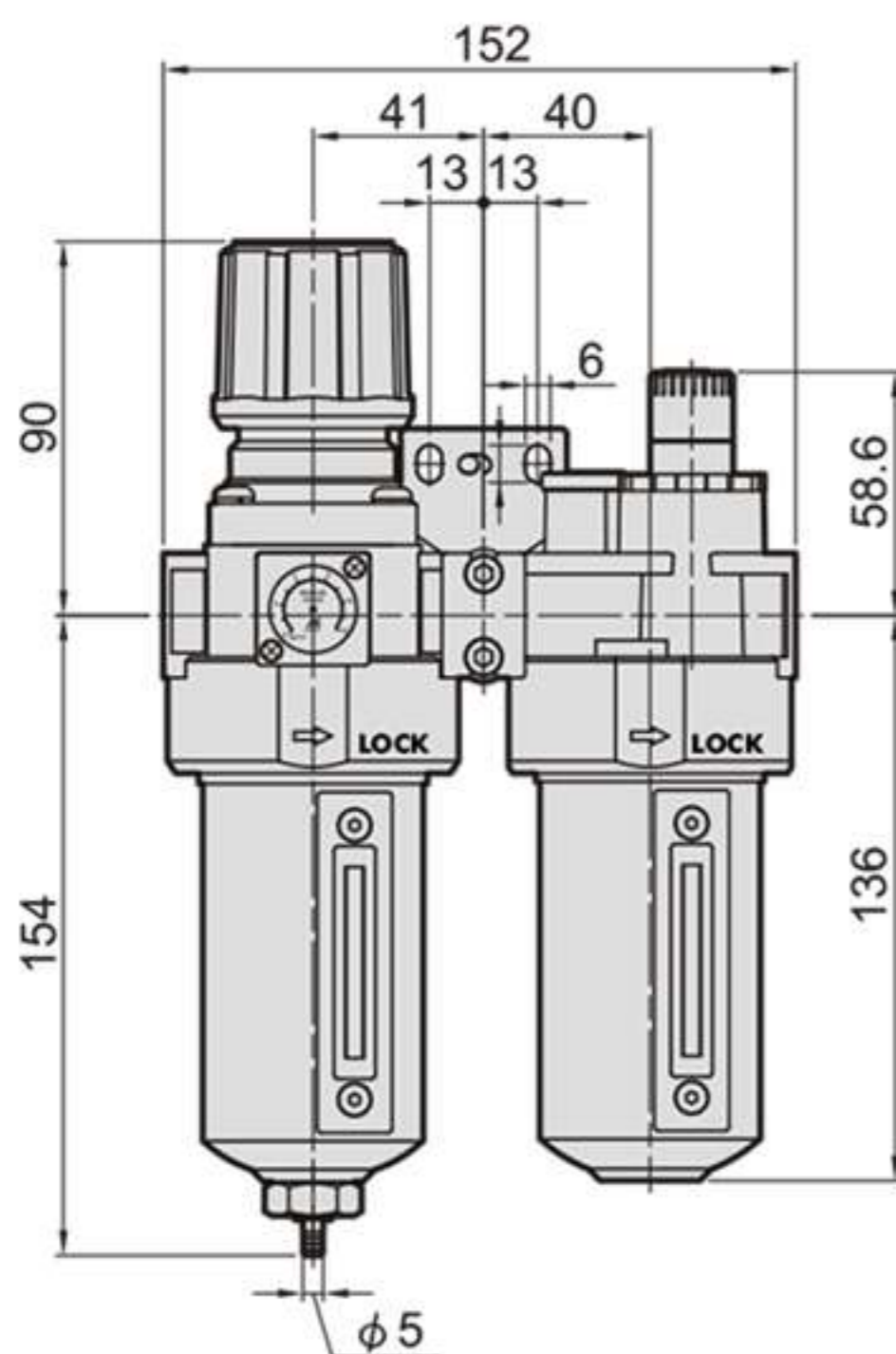
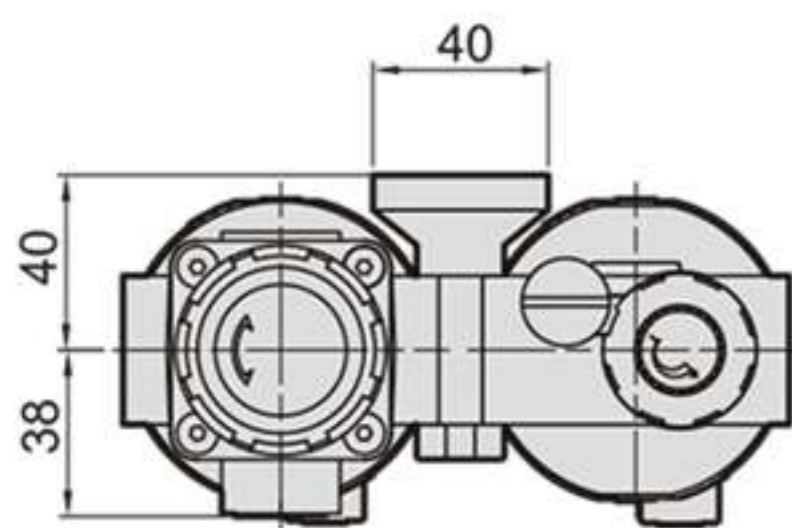

Symbol:

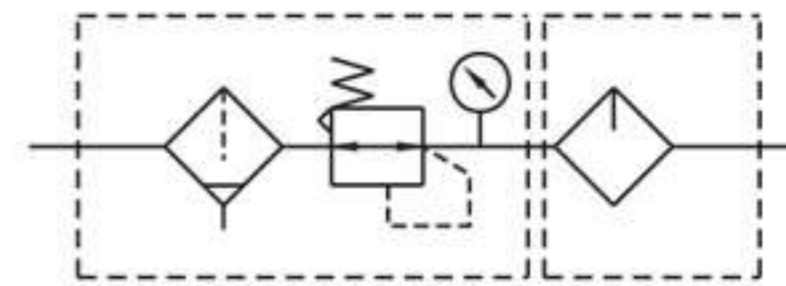

Flow feature:

