

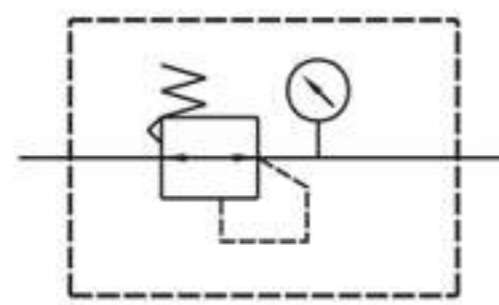

Symbol:



Specification

Model	FRL		
Port size	1/4	3/8	1/2
Media	Air		
Operating pressure range	0 ~ 15 Bar.		
Proof pressure	20 Bar.		
Regulated pressure range	Standard type: 1 ~ 8.5 Bar.		
	High pressure type: 1 ~ 15 Bar.		
Ambient temperature	(-5) ~ + 60 °C (No freezing)		
Attachment	Pressure gauge (PG-20), L-type bracket		
Weight	450 g.		

Order example:

FRL - XR05

MODEL

XR05: 1/4"

XR06: 3/8"

XR07: 1/2"

XR08: 3/4"

XR09: 1"

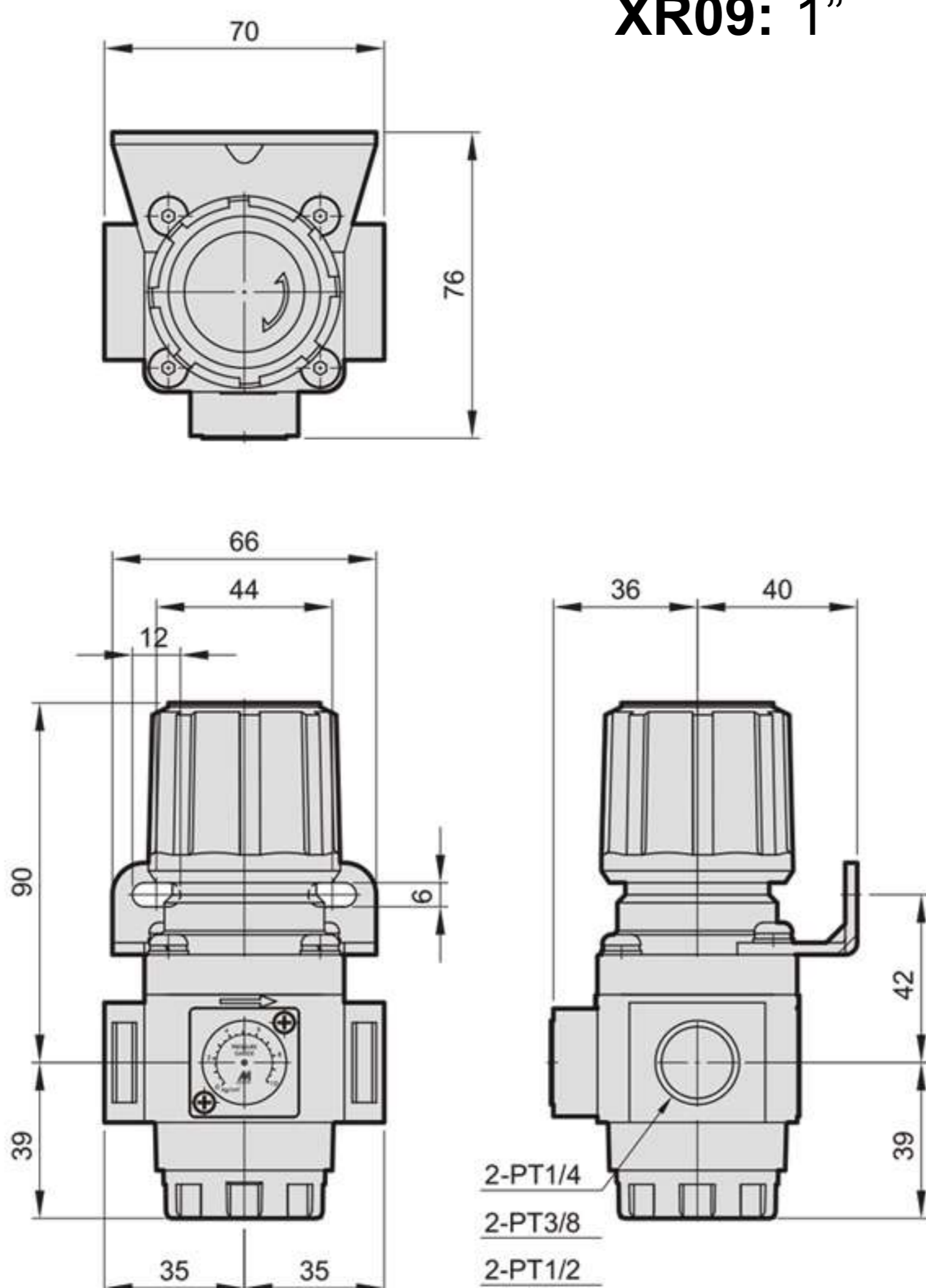

Flow feature:

